

» MWF400+

Average temperature sensor

thermokon[®]
HOME OF SENSOR TECHNOLOGY

Datasheet

Subject to technical alteration
Issue date: 16.10.2019 • A101



» APPLICATION

Duct averaging temperature sensor with flexible sensor rod in the newly developed hinged lid enclosure USE-S for measuring the average temperature in air ducts.

» TYPES AVAILABLE

Duct averaging sensor temperature – passive

MWF400+ <sensor>

Duct averaging sensor temperature – active TRV 0..10 V | TRA 4..20 mA

MWF400+ TRV MultiRange

MWF400+ TRA MultiRange

<sensor>: PT100/PT1000/NTC10K/NTC20K/NTC1,8K/Ni1000/Ni891/Ni1000TK5000

MultiRange: Measuring ranges adjustable at the transducer

» SECURITY ADVICE – CAUTION



The installation and assembly of electrical equipment should only be performed by authorized personnel.

The product should only be used for the intended application. Unauthorised modifications are prohibited! The product must not be used in relation with any equipment that in case of a failure may threaten, directly or indirectly, human health or life or result in danger to human beings, animals or assets. Ensure all power is disconnected before installing. Do not connect to live/operating equipment.

Please comply with

- Local laws, health & safety regulations, technical standards and regulations
- Condition of the device at the time of installation, to ensure safe installation
- This data sheet and installation manual

» NOTES ON DISPOSAL



As a component of a large-scale fixed installation, Thermokon products are intended to be used permanently as part of a building or a structure at a pre-defined and dedicated location, hence the Waste Electrical and Electronic Act (WEEE) is not applicable. However, most of the products may contain valuable materials that should be recycled and not disposed of as domestic waste. Please note the relevant regulations for local disposal.

» GENERAL REMARKS CONCERNING TO SENSORS

Especially with regard to passive sensors in 2-wire conductor versions, the wire resistance of the supply wire has to be considered. If necessary the wire resistance has to be compensated by the follow-up electronics. Due to self-heating, the wire current affects the measurement accuracy. So it should not exceed 1 mA.

When using lengthy connection wires (depending on the cross section used) the measuring result might be falsified due to a voltage drop at the common GND-wire (caused by the voltage current and the line resistance). In this case, 2 GND-wires must be wired to the sensor - one for supply voltage and one for the measuring current.

Sensing devices with transducer should always be operated in the middle of the measuring range to avoid deviations at the measuring end points. The ambient temperature of the transducer electronics should be kept constant. The transducers must be operated at a constant supply voltage ($\pm 0,2$ V). When switching the supply voltage on/off, onsite power surges must be avoided.

» BUILD-UP OF SELF-HEATING BY ELECTRICAL DISSIPATIVE POWER

Temperature sensors with electronic components always have a dissipative power, which affects the temperature measurement of the ambient air. The dissipation in active temperature sensors shows a linear increase with rising operating voltage. This dissipative power has to be considered when measuring temperature. In case of a fixed operating voltage ($\pm 0,2$ V) this is normally done by adding or reducing a constant offset value. As Thermokon transducers work with a variable operating voltage, only one operating voltage can be taken into consideration, for reasons of production engineering. Transducers 0..10 V / 4..20 mA have a standard setting at an operating voltage of 24 V =. That means, that at this voltage, the expected measuring error of the output signal will be the least. For other operating voltages, the offset error will be increased by a changing power loss of the sensor electronics. If a re-calibration should become necessary later directly on the sensor, this can be done by means of a trimming potentiometer on the sensor board.

Remark: Occurring draft leads to a better carrying-off of dissipative power at the sensor. Thus temporally limited fluctuations might occur upon temperature measurement.

» PRODUCT TESTING AND CERTIFICATION



Declaration of conformity

The declaration of conformity of the products can be found on our website <https://www.thermokon.de/>.

» USE ENCLOSURE WITH UV AND WEATHER RESISTANCE

After some time, outdoor mounted plastics can lose their color and quality. Therefore, all USE housings are made of special white polycarbonate (PC). The light-stable colorants and additives are used to achieve optimum protection of the polymer while maintaining color stability. The titanium dioxide used is specially developed for polycarbonate and offers excellent UV protection through the reflection of the entire light spectrum including the UV component by 340 nm. This effectively counteracts the otherwise occurring photochemical polymer degradation. The colors stay full for a long time without fading. The material is also resistant to cold and frost.

» TECHNICAL DATA

Measuring values	temperature		
Output voltage (type-dependent)	TRV 1x 0..10 V or 0..5 V, min. load 5 k Ω		
Output ampere (type-dependent)	TRA 1x 4..20 mA, max. load 500 Ω		
Output passive (type-dependent)	passive optional, PT100/PT1000/NTC10K/NTC20K/NTC1,8K//Ni1000/Ni891/Ni1000TK5000		
Power supply (type-dependent)	TRV 15..24 V = (\pm 10%) or 24 V ~ (\pm 10%) SELV	TRA 15..24 V = (\pm 10%) SELV	
Power consumption (type-dependent)	TRV typ. 0,4 W (24 V =) 0,8 VA (24 V ~)	TRA typ. 0,5 W (24 V =)	
Measuring range temp. (type-dependent)	passive -30..+80 °C, depending on used sensor		
Output signal range temp. *Scaling analogue output (type-dependent)	TRV TRA default setting: -20..+80 °C selectable from 8 temperature ranges -50..+50 -20..+80 -15..+35 -10..+120 0..+50 0..+100 0..+160 0..+250 °C, adjustable at the transducer		
Operating temperature range * Max. permissible operating temp	sensor rod -30..+80 °C	electronic enclosure -35..+70 °C	mounting base -35..+90 °C
Accuracy temperature (type-dependent)	TRV TRA \pm 0,5 K (typ. at 21 °C within default measuring range)	passive Pt1000: DIN class B Ni1000/Ni891/Ni1000TK5000: \pm 0,4 K (typ. at 0 °C) NTC10k: \pm 0,22 K (typ. at 25 °C)	
Enclosure	enclosure USE-S, PC, pure white, with removable cable entry, UV resistant		
Protection	IP65 according to EN 60529		
Cable entry	Flextherm M20, for wire \varnothing =4,5..9 mm, removable		
Connection electrical	removable plug-in terminal, max. 2,5 mm ²		
Sensor rod	copper, \varnothing =4 mm, mounting length: 400 mm, sensor neck stainless steel V4A \varnothing =6 mm		
Ambient condition	max. 85% rH short term condensation		

» MOUNTING ADVICES

The sensor can be mounted to the ventilation duct by means of the mounting clip. During the installation, observe that the bending radius of the sensor rod has to be no smaller than 35 mm. **Note: Please pay attention to the sensor rod while mounting and protect it from mechanical damage!**

» CONNECTION PLAN AND CONFIGURATION

The adjustment of the measuring ranges is made by changing the jumpers in a de-energized state. The output value of the new measuring range is available after 2 seconds.

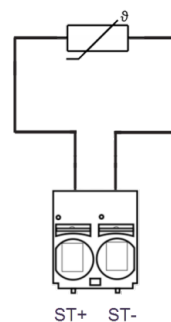
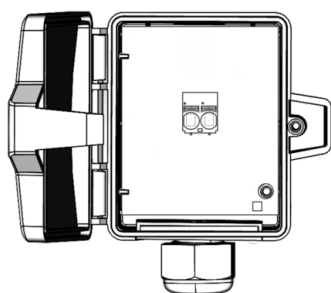

fig. (terminal assignment passive sensor)

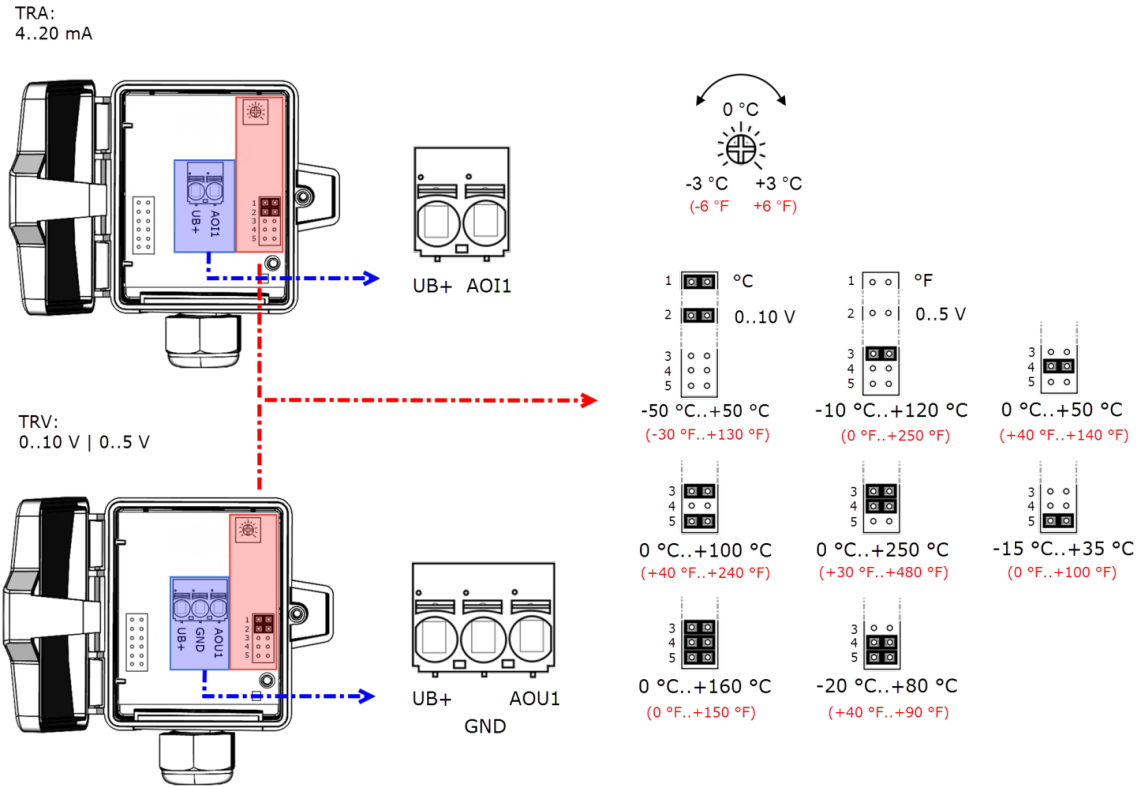
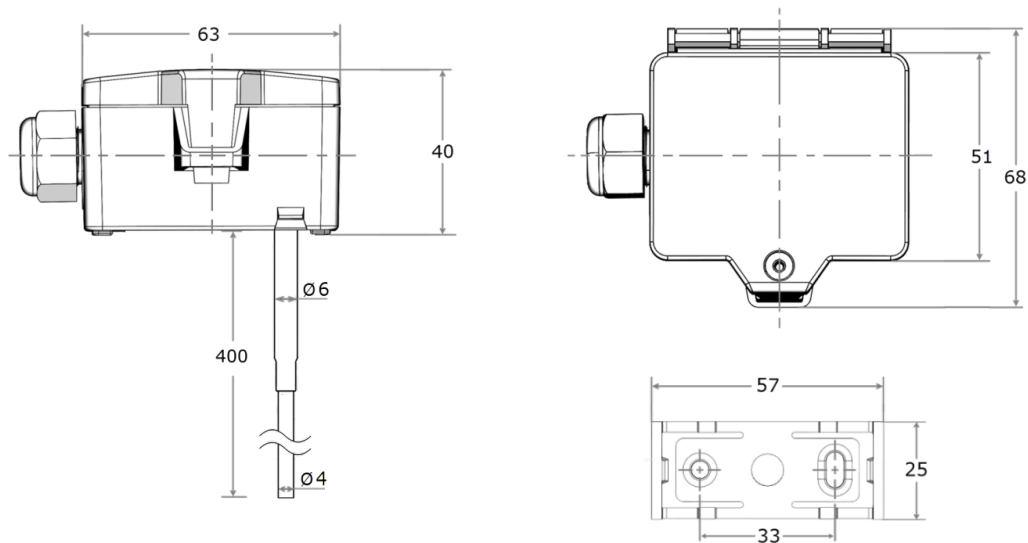

fig. (Measuring range and offset adjustment, default settings: -20 °C..+80 °C | 0 K)

» DIMENSIONS (MM)



» ACCESSORIES (INCLUDED IN DELIVERY)

Mounting kit universal
 • Cover screw + screw cover • 2 Rawlplugs • 2 Screws (countersunk head) • 2 Screws (rounded head)

Item No. 698511

» ACCESSORIES (OPTIONAL)

Mounting base enclosure USE pure white
 Mounting flange MF6 flexible (incl. inserts for Ø=4 | 6 | 7 mm)
 Sealing insert M20 USE white, 2x Ø=7 mm (for 2 wire; PU 10 pieces)

Item No. 667722

Item No. 399098

Item No. 641333