

Datasheet

Subject to technical alteration
Issue date: 18.06.2018 • A001



Application

Room operating unit for room/space temperature measurement with fan stage adjustment and manual override. Designed for control and monitoring systems.

Types Available

Room sensor temperature – active Modbus

WRF06 AO2V Modbus <Switch ranges>

WRF06 DI4 Modbus <Switch ranges>

<Switch ranges>: see technical data

Security Advice – Caution



The installation and assembly of electrical equipment should only be performed by authorized personnel.

The product should only be used for the intended application. Unauthorised modifications are prohibited! The product must not be used in relation with any equipment that in case of a failure may threaten, directly or indirectly, human health or life or result in danger to human beings, animals or assets. Ensure all power is disconnected before installing. Do not connect to live/operating equipment.

Please comply with

- Local laws, health & safety regulations, technical standards and regulations
- Condition of the device at the time of installation, to ensure safe installation
- This data sheet and installation manual

Notes on Disposal



As a component of a large-scale fixed installation, Thermokon products are intended to be used permanently as part of a building or a structure at a pre-defined and dedicated location, hence the Waste Electrical and Electronic Act (WEEE) is not applicable. However, most of the products may contain valuable materials that should be recycled and not disposed of as domestic waste. Please note the relevant regulations for local disposal.

General remarks concerning sensors

Especially with regard to passive sensors in 2-wire conductor versions, the wire resistance of the supply wire has to be considered. If necessary the wire resistance has to be compensated by the follow-up electronics. Due to self-heating, the wire current affects the measurement accuracy, so it should not exceed 1 mA.

When using lengthy connection wires (depending on the cross section used) the measuring result might be falsified due to a voltage drop at the common GND-wire (caused by the voltage current and the line resistance). In this case, 2 GND-wires must be wired to the sensor - one for supply voltage and one for the measuring current.

Sensing devices with a transducer should always be operated in the middle of the measuring range to avoid deviations at the measuring end points. The ambient temperature of the transducer electronics should be kept constant. The transducers must be operated at a constant supply voltage ($\pm 0,2$ V). When switching the supply voltage on/off, onsite power surges must be avoided.

Remarks to Room Sensors

Location and Accuracy of Room Sensors

The room sensor should be mounted in a suitable location for measuring accurate room temperature. The accuracy of the temperature measurement also depends directly on the temperature dynamics of the wall. It is important, that the back plate is completely flush to the wall so that there is sufficient circulation of air through the vents in the cover, otherwise, deviations in temperature measurement will occur due to uncontrolled air circulation. The temperature sensor should not be covered by furniture or other objects. Mounting next to doors (due to draught) or windows (due to colder outside wall) should be avoided.

Surface and Flush Mounting

The measuring result is influenced by the thermal characteristics of the wall. A solid concrete wall responds to thermal fluctuations within a room in a much slower than a light-weight structure wall. Room temperature sensors installed in flush-mounted boxes have a longer response time to thermal variations. In extreme cases they detect the radiant heat of the wall even if the air temperature in the room is lower for example. The quicker the dynamics of the wall (temperature acceptance of the wall) or the longer the selected inquiry interval of the temperature sensor is the smaller the deviations limited in time are.

Build-up of Self-Heating by Electrical Dissipative Power

Temperature sensors with electronic components always have a dissipative power, which affects the temperature measurement of the ambient air. The dissipation in active temperature sensors shows a linear increase with rising operating voltage. This dissipative power has to be considered when measuring temperature. In case of a fixed operating voltage ($\pm 0,2$ V) this is normally done by adding or reducing a constant offset value. If a re-calibration should become necessary later directly on the sensor, this can be done by means of a trimming potentiometer on the sensor board. As Thermokon transducers work with a variable operating voltage, only one operating voltage can be taken into consideration, for reasons of production engineering. Transducers have a standard setting at an operating voltage of 24 V =. That means, that at this voltage, the expected measuring error of the output signal will be the least. For other operating voltages, the offset error will be increased by a changing power loss of the sensor electronics.

Remark: Occurring draft leads to a better carrying-off of dissipative power at the sensor. Thus temporally limited fluctuations might occur upon temperature measurement.

Technical Data	
Measuring values	temperature
Output voltage	AO2V 2x 0..10 V, min. Last 5 kΩ
Network technology	RS485 Modbus, RTU, half-duplex, baud rate 4.800, 9.600, 19.200, 38.400 or 57.600, parity: non (2 stopbits), even or odd (1 stopbit)
Power supply	15..24 V = (±10%) or 24 V ~ (±10%)
Power consumption	typ. 0,9 W (24 V =) 1 VA (24 V ~)
Measuring range temperature	0..+50 °C
Operating temperature range	max. permissible operating temperature 0..+50 °C
Accuracy temperature	±1% of Measuring range (typ. at 21 °C)
Inputs	DI4 4x for floating switching contacts
Switch range Berker	S.1, B.3 aluminum, B.7 glass, Q.1, Q.3, K.1, K.5 aluminum stainless steel
Switch range Busch-Jaeger	Busch-balance® SI, Busch-Duro 2000® SI, Reflex SI, solo®, future® linear, impuls, Busch-axcent®, alpha nea®
Switch range Feller	EDIZIOdue
Switch range Gira	E2, E3, Standard 55, Esprit, Event, F100
Switch range Jung	LS 990, A 500, AS 500, A plus, A creation, CD 500
Switch range Merten	M-Smart, M-Arc, M-Plan, 1-M, Atelier-M, M-Pure, Artec, Artec stainless steel, Antique
Switch range Peha	Aura, Aura glass
Protection	IP20 according to EN 60529
Connection electrical	terminal block, max. 1,5 mm², pluggable
Ambient condition	max. 85% rH non-condensing
Mounting	flush mounted in standard EU box (Ø=55 mm)
Notes	for other frame designs please request

Connection Plan

WRF06 AO2V Modbus

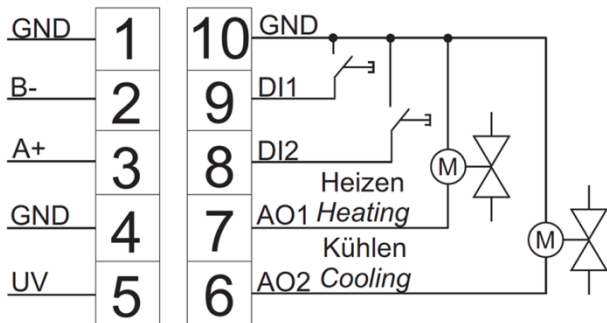

WRF06 DI4 Modbus

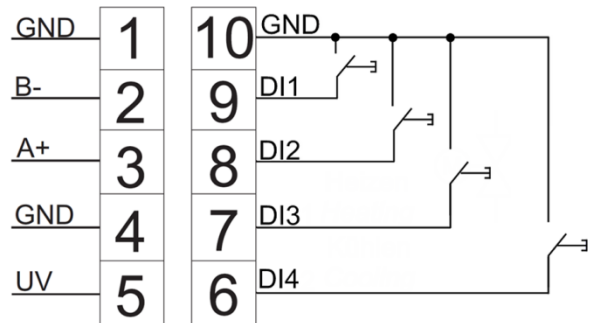

Configuration

Jumper set: Termination (120 Ohm) enabled

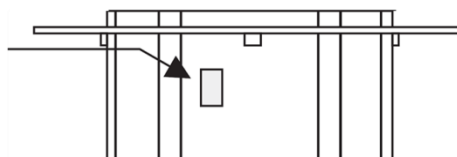

DIP switch configuration device parameter

1	2	3	4	5	
off	XX	XX	XX	XX	(default) Mode RTU
on	XX	XX	XX	XX	Mode ASCII
XX	off	off	XX	XX	(default) Baud 9600
XX	on	off	XX	XX	Baud 19200
XX	off	on	XX	XX	Baud 38400
XX	on	on	XX	XX	Baud 57600
XX	XX	XX	off	off	Parity no
XX	XX	XX	on	off	(default) Parity even
XX	XX	XX	off	on	Parity odd

DIP switch configuration device address

binary coded

1	2	3	4	5	
off	off	off	off	off	0 Device Address
on	off	off	off	off	1 (default) Device Address
off	on	off	off	off	2 Device Address
on	on	off	off	off	3 Device Address
:	:	:	:	:	:
on	on	on	on	on	31 Device Address

Software:

The configuration software and more information about the parameter of the WRF06 Modbus, please download from the following link: <http://www.thermokon.de/en/produkte/temperatur/raumfuehler/wrf06.html#tabs-downloads>



Dimensions (mm)

WRF06 Modbus + Gira E2

